



Pepper Grinder and Salt Shaker

Dimension Notes

The dimensions given on Figure 2 are for the inside bore of the wooden body of the grinder. The outside dimensions will vary to suit the design, but the wall thickness should be at least $\frac{3}{16}$ ". The length of the main wooden body and cap will vary, depending upon the size of grinder mechanism chosen, but the various bore dimensions will always remain the same. The **finished** length of the body/cap must be $\frac{1}{8}$ " ($\pm \frac{1}{16}$ ") longer than the shaft of the mechanism. In other words, a 6" mechanism will fit in a finished body/cap with a length of $6\frac{1}{8}$ ", a 10" mechanism in a $10\frac{1}{8}$ " tall (long) grinder body/cap, etc. When determining the length of your blank be sure to allow extra length for tenons, parts, and material to be held by turning chuck jaws.

Turning Notes

We recommend using a scroll jaw or collet chuck for the complete turning operation. The wood blank used should allow for making the body and cap as well as the waste held in the chuck and parted off during turning. The base of the grinder will be on the tailstock end of the lathe.

Turning Method #1

1. Cut the internal step used to accommodate the grinding mechanism base (Fig. 2). This hole would be $1\frac{5}{8}$ " diameter and $\frac{1}{2}$ " or deeper in depth.
2. Center and bore a $1\frac{1}{16}$ " diameter hole in the wooden blank to create the cavity for holding the peppercorns, grinding mechanism, and internal spindle. This hole can be cut using turning tools or by using a $1\frac{1}{16}$ " diameter multi-spur bit.
3. If a multi-spur bit is used, the bit should be held by a Jacob's chuck in the tailstock of your lathe. Set your lathe speed for approximately 500-700 RPM and drill to depth by advancing the tailstock/multi-spur bit into the wood blank. It helps if the bottom surface of the wood blank is faced or turned flat before drilling. This center hole should be bored completely through the length of the body plus about $\frac{1}{4}$ " for the tenon (Fig. 2).
Tip: In most cases your multi-spur bit will not be long enough to bore completely through the body blank. If this is the case, bore as deeply as possible with the multi-spur, then retract the bit from the boring. Remove the multi-spur bit and insert a spade bit

in the tailstock. The walls of the partially bored multi-spur hole will serve as a guide, and allow you to use the longer spade bit to complete the boring. If necessary, you can use a spade bit extension for longer borings.

4. The shoulder where the $1\frac{1}{16}$ " diameter bore meets the original $1\frac{5}{8}$ " hole should be slightly rounded over with a gouge or scraper to facilitate installation of the mechanism shaft (Fig. 1).

5. With a parting tool, cut the tenon for the cap on the main body, then part off the base (Fig. 2). The stock remaining in the chuck will be used to create the grinder cap. Turn a recess in the cap which will accept the tenon of the main body. Turn the recess $\frac{1}{16}$ " deeper than the length of the main body tenon to allow for cap movement. Lastly, drill a $\frac{1}{4}$ " diameter hole through the center of the cap for the grinder mechanism shaft.

6. Place the tenon of the wooden body into the recess of the cap and with the help of a conical plug hold the entire assembly in place with the ball bearing tailstock (Fig. 3). Complete the turning, matching the cap and body. Test the fit of the cap and if necessary sand the recess in the cap so that it fit loosely and rotates without binding on the tenon. Part off the finished cap.

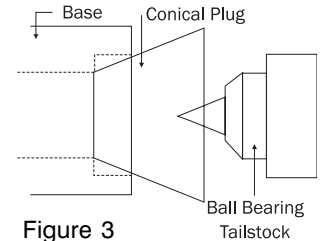

Figure 3

Turning Method #2

1. All turnings and boring for the body are the same as Method 1 except that no tenon is cut on the top of the wooden body. Instead, after parting the body from the cap, turn a 1" diameter by $\frac{1}{4}$ " long tenon on the bottom of the cap (Fig. 1). Drill a $\frac{1}{4}$ " hole through the cap.
2. Place center bore of the wooden body onto the cap tenon and with the help of a conical plug (Fig. 3) hold the entire assembly in place with the ball bearing tailstock. Complete the turning, matching the cap and body. Test the fit of the cap and if necessary sand the cap tenon so that it fit loosely and rotates without binding in the wooden body. Part off the finished cap.

Figure 1

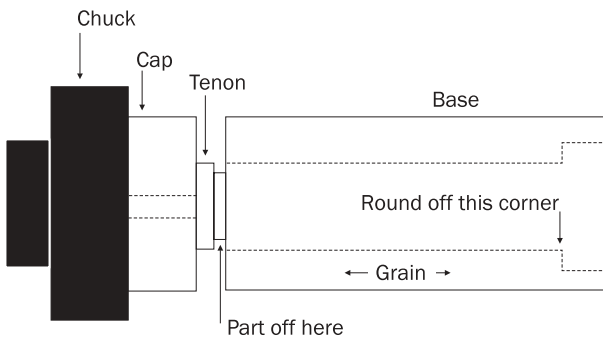
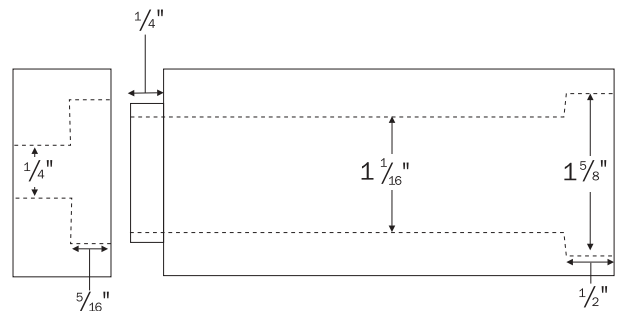

Figure 2





Pepper Grinder and Salt Shaker

Product #126637, 126638, 126639, 126640, 126725

Installing the Mechanism

1. Slide the Shaft Spring Retainer (D) into the bottom of the 1 1/16" hole so that the flanges with the screw holes catch on the lip of the body. Insert the Grinder Housing (H) so that the notches in the Grinder Housing align with the flanges of the Shaft Spring Retainer (D). If necessary notch the interior edges of the 1 1/16" bore slightly with a sharp knife to allow the Grinder Housing (H) to completely seat on the retaining lip.

2. With the grinder housing completely seated on the retaining lip and the shaft spring retainer's flanges held in place by the notches on the grinder housing, mark the location of the spring retainers mounting holes with an awl. Remove both the grinder housing and shaft spring retainer and drill pilot holes for the mounting screws at the locations just marked. Replace the shaft spring retainer and grinder housing in the body, but do not screw into place at this point.

3. Remove the Top Knob (A) from the Shaft (C) and from the bottom, insert the shaft with Spring (E) through the Grinder Housing, Shaft Spring Retainer, and wooden body until the Grinder (G) sits inside the Grinder Housing. Place the Grinder Shaft Retainer (F) over the bottom of the installed grinder shaft so that the opening of the "U" shaped retainer faces the top of the grinder body (Fig. 4).

4. Line up the mounting screw holes of the Grinder Shaft Retainer (F) with the mounting screw holes in the Shaft Spring Retainer (D) and the pilot holes previously drilled. Use two of the included screws to secure all parts to the grinder body.

5. Next, prepare the grinder cap by centering the Shaft Drive Plate (B) over the 1/4" hole in the recess turned in the bottom of the cap (Method 1) or on the bottom of the tenon (Method 2). Secure it with the two screws included.

6. Slide the cap over the grinder shaft until it seats against the grinder body. Secure by screwing the Top Knob (A) onto the shaft.

Filling and Use

Remove the Top Knob (A), fill pepper chamber 3/4 full of peppercorns and then reassemble. When dispensing pepper always turn the top of the grinder to the right (clockwise).

Salt Shaker

Turning Notes

1. Cut the internal step used to accommodate the bottom plug (Fig. 5). This hole would be 1 1/4" diameter and at least 1/4" deep.

2. Drill a 1" hole, stopping at least 1/4" short of drilling completely through the shaker body.

3. Drill a 3/4" hole, centered through the top of the body into the 1" through hole.

Assembly

1. Using two part epoxy glue the Stainless Shaker Top (A) into the 3/4" top hole.

2. Push the red plastic Bottom Plug (B) into the 1 1/4" diameter bottom hole. Any portion of the red "pull tab" that extends below the base of the shaker may be trimmed off with a knife.

Figure 4

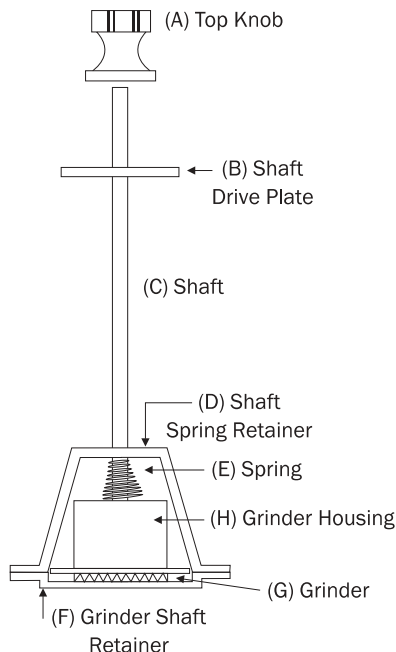

Figure 5

